



Hyzon

Rigid Chassis

Models and versions

hyzonmotors.com.au



Vehicle Details

Hyzon Rigid Chassis

HYDROGEN ELECTRIC POWERTRAIN

Electric motor power	210 kW continuous, 410kW peak
Fuel cell power	110 kW Single fuel cell stack
Electric motor torque	1100 Nm continuous (737 lb-ft), 2400 Nm peak (1770 lb-ft)
Transmission	4 Speed with PTO options
High voltage battery energy	55 kWh
Hydrogen storage	25 kg (typical)
Storage pressure	350 bar, 35 MPa
Typical range (application dependent)	200-400 km

CHASSIS

Wheelbases from 3750mm - 6200mm
Continuous hole pattern, 50 mm hole spacing
Side member height 279mm
Low chassis height 900mm unladen
Integrated FUPD bumper
Ground clearance 195mm front (adjustable)
Ground clearance 200mm rear (adjustable)

COLOURS

White cabin with black chassis

Optional Other cab/chassis colours available

SUSPENSION AND AXLES

Front	8,000 kg capacity with 2 x air springs and stabiliser bar
Rear	2 x 13,000 kg capacity axles with difflocks and 4 air springs per axle
Height lower and raise feature	

WHEELS AND TYRES

Tyre type	295/80R 22.5
Rim	10 stud steel 9.00 x 22.5

BRAKES

Front and rear disc brakes
Electronic braking system (EPB)
Anti-Lock braking system (ABS)
Electronic stability program (ESP)
Acceleration skid control (ASR)
Dual circuit air brake system with air dryer
Regenerative braking

CAB

Single control option with high roof
Seating for driver and up to 3 passengers
Climatic control/AC
Low cab height for safe entry
Optional Factory dual control with low roof
Optional Bus door with high roof

CAB EXTERIOR

Ergonomic workplace
Low-entry concept
Panorama glazing
ECE-R29/02 compliant cab
Aluminium space cage
Wide opening doors for ease of entry

VEHICLE SAFETY

Lane keeping assist

Active brake assist

Rain and light sensor

Optional: Side guard assist, Adaptive cruise control and blind spot camera

GVM

4X2 16,000 kg

6x4 26,000 kg

8x4 32,000 kg

CAB DIMENSIONS

Cab Type	BBC (mm)	Cab height (mm)	Axle to front (mm)
Low roof	2065 mm	2380mm	1880 mm
High Roof	2065 mm	2830 mm	1880 mm

4X2

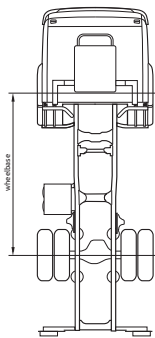

6X4/6X2

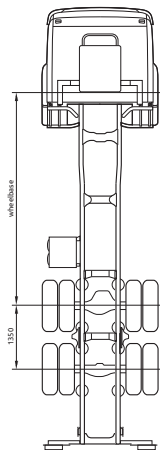

8X4

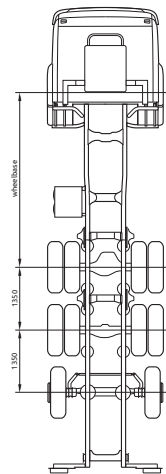

LOW CAB

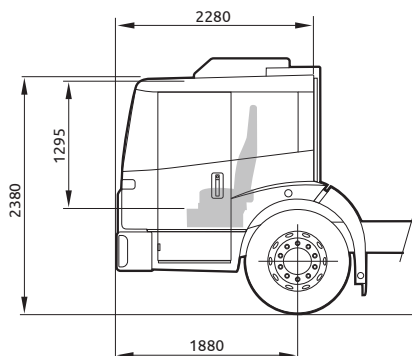

HIGH CAB

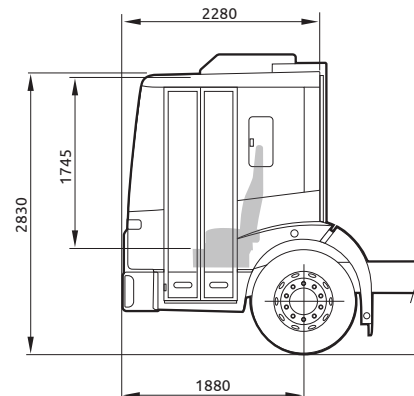

A new industrial revolution, powered by hydrogen



+ + + + + + + + + + +
+ + + + + + + + + + +
+ + + + + + + + + +
+ + + + + + + + +
+ + + + + + + +
+ + + + + + +
+ + + + + +
+ + + + +
+ + + +
+ + +
+ +
+

For more information
salesanz@hyzonmotors.com

hyzonmotors.com.au